

TOP TIER

STORAGE PRODUCTS

3-Tier Locker Assembly

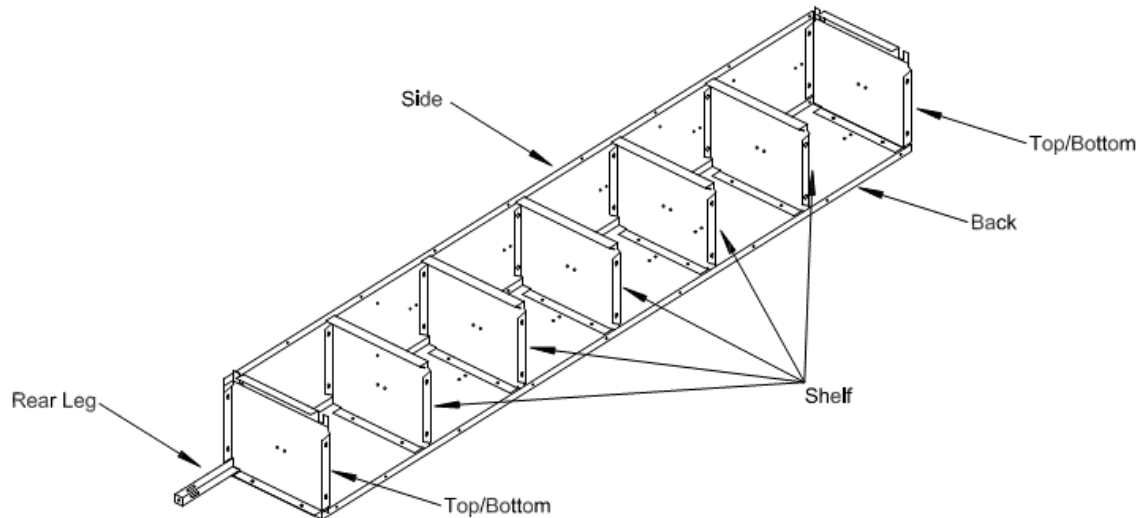

Note: Just finger tighten all nuts and bolts until locker is fully assembled. Locker screws are designed to strip for security when tightened.

- 1) Lay back panel on floor or saw horses with flanges facing up.
- 2) Bolt top and bottom to the back panel. Top, bottoms are identical and are the ones with the flanges facing out.

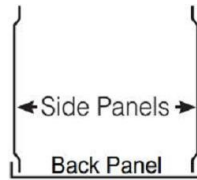

- 3) Bolt side panel inside of back panel flange. If legs are needed bolt leg to the bottom to holes of back and side panels. Note: Do not use an impactor or drill to tighten rear leg screws. It is best to use nut driver or socket wrench so not to over tighten for adjustability.
- 4) Bolt intermediate shelf to side panel. Use 12" spacing on intermediate shelves. Shelves are the ones with double bends across the front.

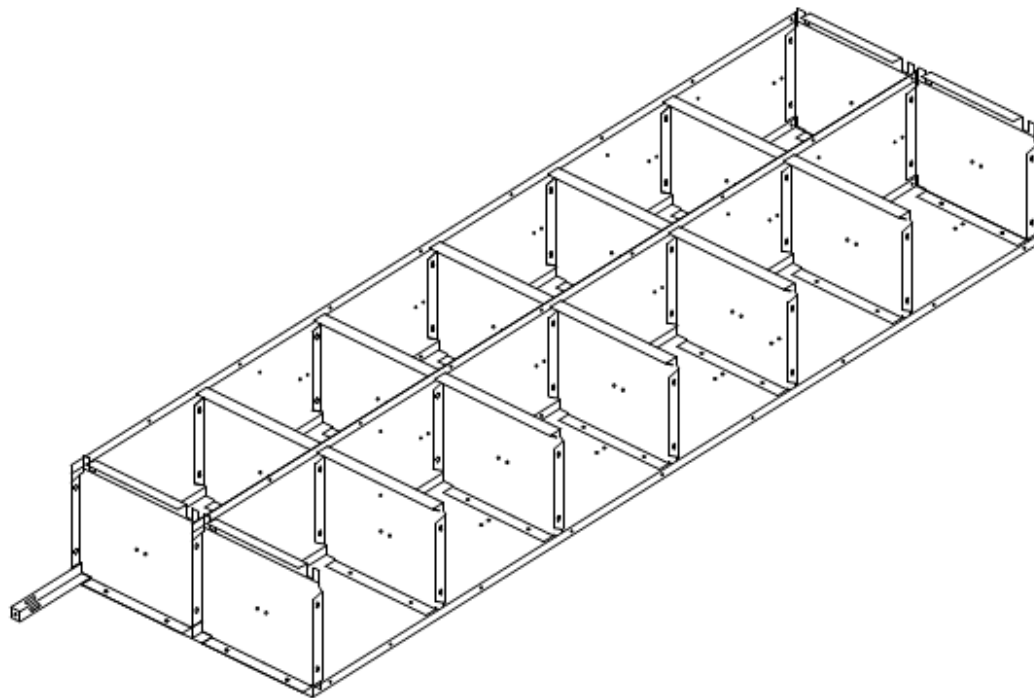

- 5) Bolt top and bottom to the next back.
- 6) Bolt side panel, top bottom, and the next back to the first assembled section.
- 7) Bolt shelves on both side of the second side panel.

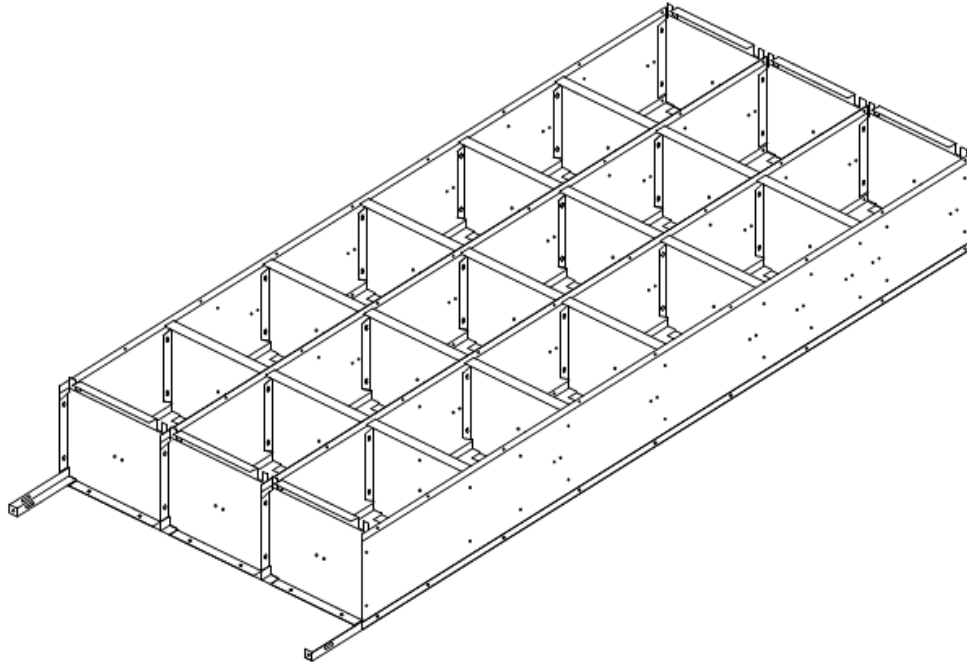

- 8) Repeat steps 5,6, and 7 until the number of frames for the group are assembled.
- 9) Bolt end side panel with rear leg if needed to the last back panel, top, bottom, and shelves.

Note: Rear legs should not exceed 54" spacing.

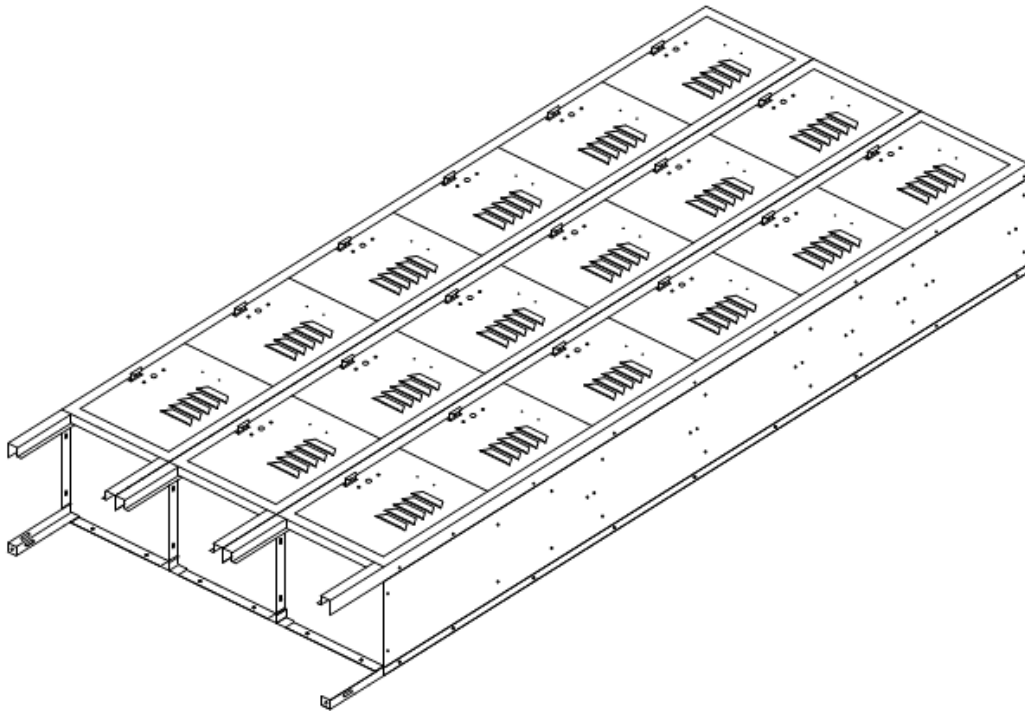

- 10) Place doors on the bodies with sides, tops and bottoms inside the door frames and bolt to sides, tops and bottoms. Note: if adjoining two or more banks in a row, omit door frame bolts on the ends of the banks to stitch locker bank together.

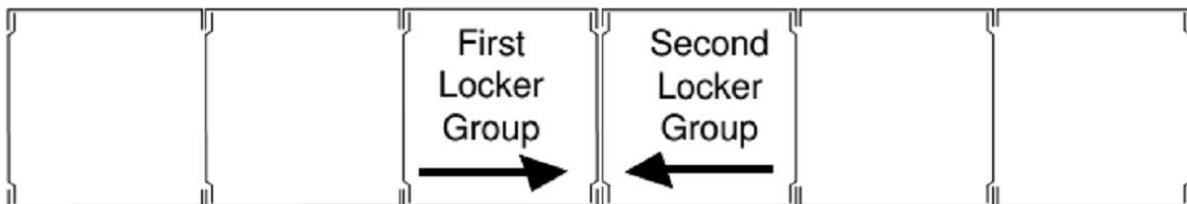

- 11) Set banks in place. Stitch adjoining locker banks together and anchor to wall and/or floor.
- 12) Adjust doors and latches to operate without binding.
- 13) Attach number plates to front of doors with rivets.
- 14) Install locks if needed.

WARNING: Lockers Must Be Anchored Properly To Prevent Injury From Tipping Over.