

TOP TIER

STORAGE PRODUCTS

3-Tier Locker Assembly

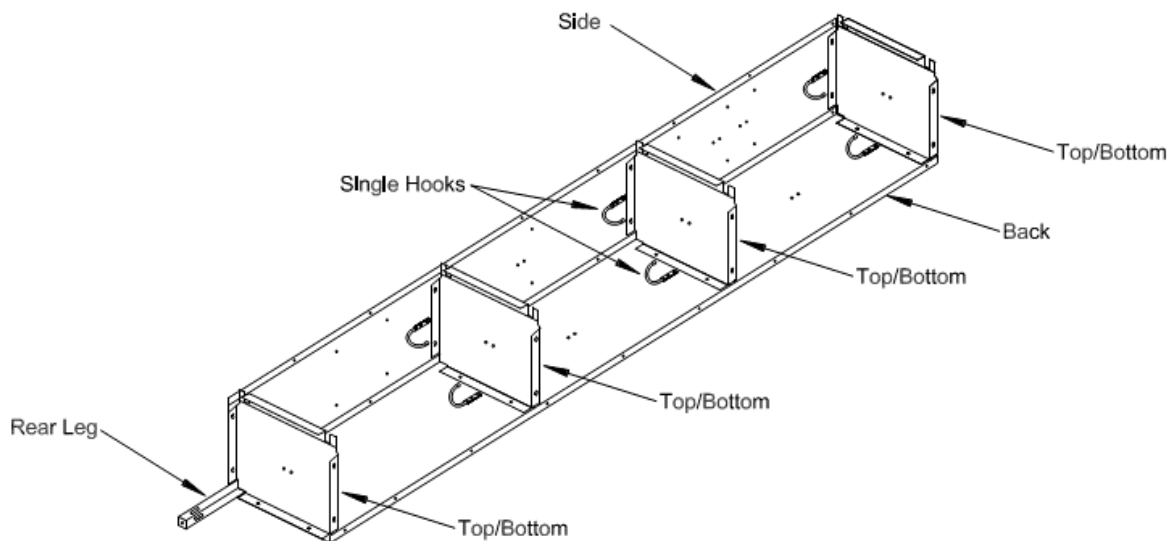

Note: Just finger tighten all nuts and bolts until locker is fully assembled. Locker screws are designed to strip for security when tightened.

- 1) Lay back panel on floor or saw horses with flanges facing up. Bolt hook to back panel. The hooks bolts to first, fourth and sixth set of holes from the top about 1-3/4", 25-1/4" and 48-3/4" down from the top.
- 2) Bolt top and bottom to the back panel. Top, bottoms and intermediates are identical and are the ones with the flanges facing out.

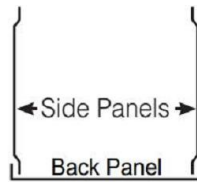

- 3) Bolt side panel inside of back panel flange. If legs are needed bolt leg to the bottom to holes of back and side panels. Note: Do not use an impactor or drill to tighten rear leg screws. It is best to use nut driver or socket wrench so not to over tighten for adjustability.
- 4) Bolt hook and intermediate shelf (top/bottom) to side panel. Use 5th and 7th set of holes down about 25" and 48" from top.

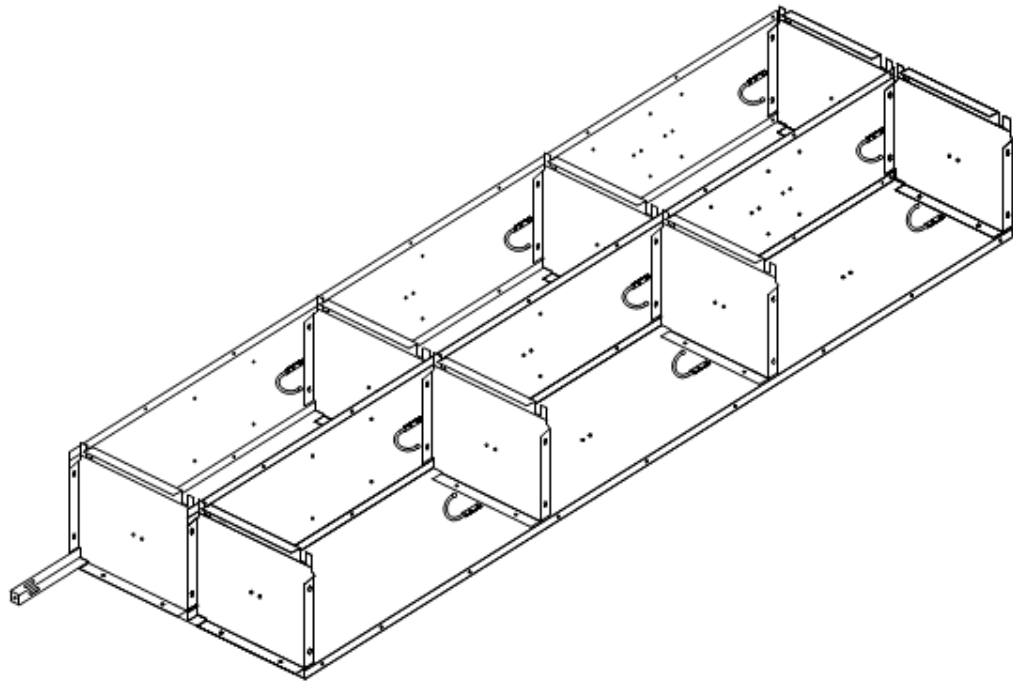

- 5) Bolt hook on next back. Bolt top and bottom to the next back.
- 6) Bolt side panel, top bottom, and the next back to the first assembled section.
- 7) Bolt shelf and hooks on both side of the second side panel.

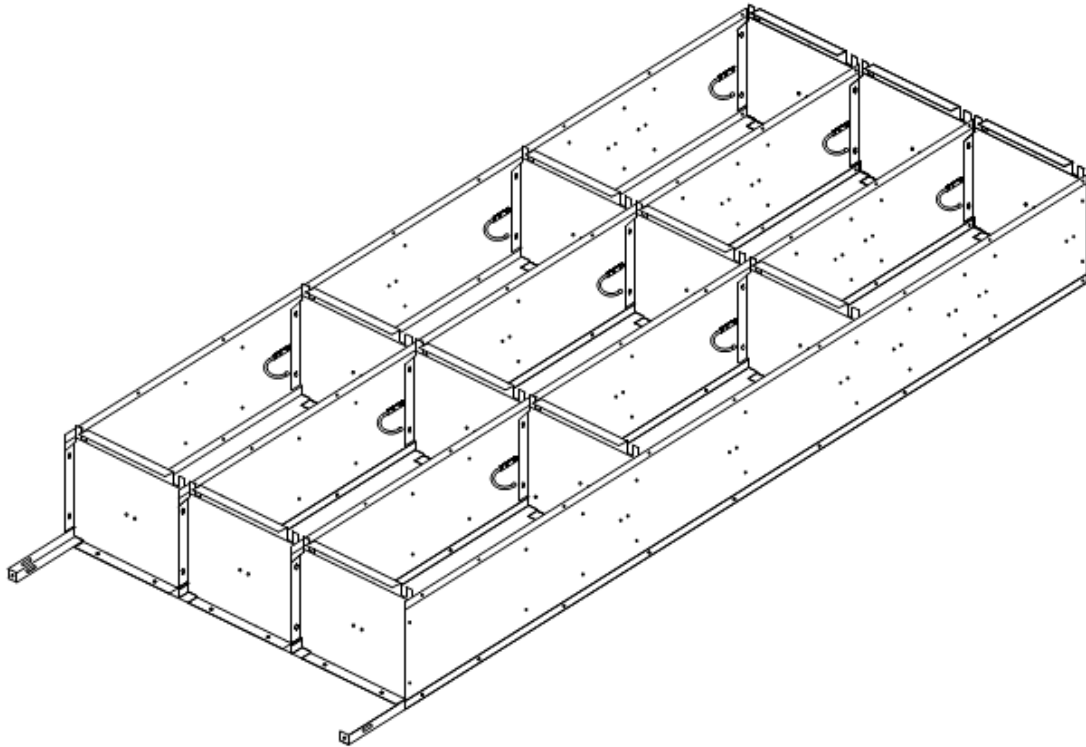

- 8) Repeat steps 5,6, and 7 until the number of frames for the group are assembled.
- 9) Bolt end side panel with hook and rear leg if needed to the last back panel, top, bottom, and shelf.
Note: Rear legs should not exceed 54" spacing.

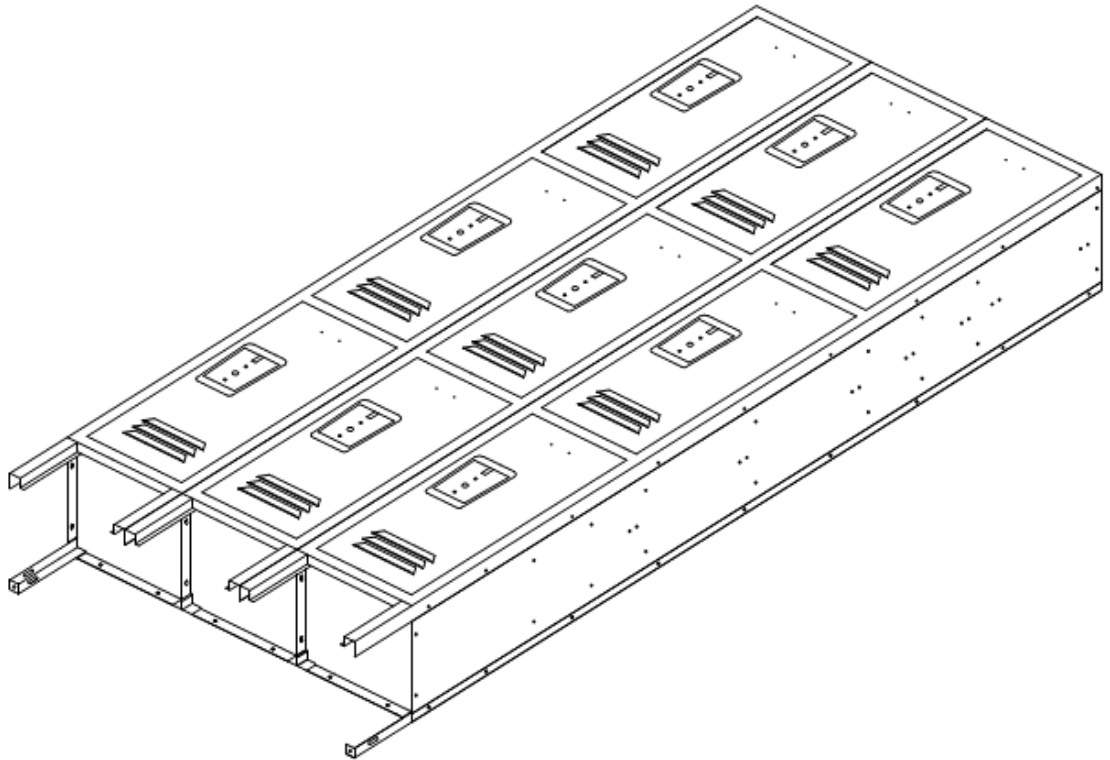

- 10) Place doors on the bodies with sides, tops and bottoms inside the door frames and bolt to sides, tops and bottoms. Note: if adjoining two or more banks in a row, omit door frame bolts on the ends of the banks to stitch locker bank together.

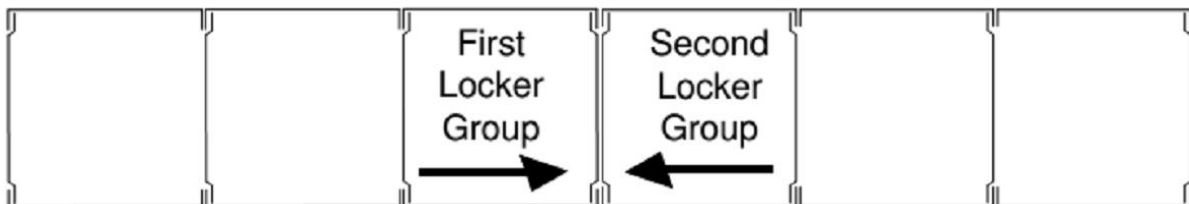

- 11) Set banks in place. Stitch adjoining locker banks together and anchor to wall and/or floor.
- 12) Adjust doors and latches to operate without binding.
- 13) Attach number plates to front of doors with rivets.
- 14) Install locks if needed.

WARNING: Lockers Must Be Anchored Properly To Prevent Injury From Tipping Over.